

Extended-range temperature-sensing ICs

Measuring at silicon's limits

Using remote temperature sensors to monitor die temperature of high-performance microprocessors and graphics processors is a common technique for managing power and thermal operating characteristics. As clock speeds, circuit densities, and power levels increase, die operating temperatures can exceed the limits of conventional temperature sensors. New temperature sensors can measure temperatures previously beyond the range of older devices. This article discusses extended-range temperature sensors, their theory, and applications.

Digital, remote temperature sensors that use an external bipolar transistor as the sensing element are widely relied on for monitoring die temperature on high-speed, high-performance ICs like microprocessors, graphics processors, and FPGAs. Monitoring temperature accurately is critically important for ensuring best performance and protecting against catastrophic failure. A temperature monitor lets the system perform fan control and clock-throttling functions to keep high-performance ICs within the necessary operating temperature ranges. At higher temperatures, it can be used to shut the system down to prevent failure. As performance and power levels increase, the remote temperature-monitoring function becomes even more important, yet is more difficult to perform.

Virtually all conventional digital temperature-sensor ICs have upper measurement limits of less than 128°C; many are limited to 100°C. Frequently, a conventional temperature range is sufficient. However, there are times when it is important to measure temperatures as high as 150°C. In such cases, extended-range temperature sensors are necessary.

Sensing extended temperatures

The typical digital temperature-sensor IC represents temperature data using one sign bit and seven magnitude bits with an LSB of 1°C and an MSB of 64°C. Although some digital sensors have a few additional bits to express temperature with more resolution, the 64°C MSB limits the highest measured temperature to less than 128°C.

An extended-range temperature sensor can measure values well above this 128°C limit—often as high as 150°C. The most convenient way of performing this task is by providing an MSB with a weight of 128°C. In this case, the temperature data range extends to 255°C, which is well beyond the useful range as it is unlikely that temperatures over 127°C will be encountered. Accuracy degrades rapidly at temperatures above approximately 150°C because of the limitations in semiconductor junctions used to measure temperature.

The maximum operating temperature for some high-power ICs depends on clock speed, process, device package, and various design factors. Often, signal integrity degrades with increasing temperature until the circuit no longer meets its specifications. In many CPUs and graphics processors, this happens around 100°C; but in some high-performance circuits, normal operation can extend to 145°C. If the device can function properly at an extended temperature, accurately measuring the temperature is important for keeping it within the correct operating range. Since the absolute maximum temperature of the die is near the top of this range, it is even more critical to monitor temperature to avoid failure and subsequent shutdown (**Figure 1**).

In some high-performance processors, the physics of the thermal diode adds an “offset” to the measured temperature. In other words, the measured temperature can be significantly higher than the real temperature. In this case, the temperature sensor needs to measure *apparent* temperatures that are much higher than the normal operating range. Although the measured temperature might be 150° or higher, the diode’s real temperature can still be within the processor’s normal operating temperature range.

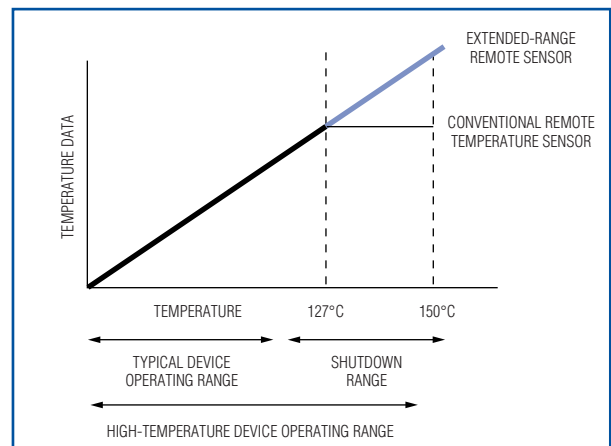

Figure 1. Extended-range remote temperature sensors can monitor high-performance devices through their full operating ranges.

Remote temperature-sensing basics

The most common approach to measuring temperature with a remote-diode temperature sensor forces two different currents through the diode, typically with a current ratio of about 10:1. (The diode is not a two-lead device like a 1N4001. Instead, it is a diode-connected bipolar transistor. The ideality factor of a two-lead diode is incompatible with remote-diode temperature sensors.) The diode's voltage is measured at each current level and the temperature is calculated based on the equation,

$$V_H - V_L = n \frac{kT}{q} \left[\ln \frac{I_H}{I_L} \right]$$

where:

I_H is the larger diode bias current

I_L is the smaller diode bias current

V_H is the diode voltage caused by I_H

V_L is the diode voltage caused by I_L

n is the ideality factor of the diode

k is Boltzmann's constant (1.38×10^{-23} joules/°K)

T is the temperature in °K

q is the charge of an electron (1.60×10^{-19} C)

If $\frac{I_H}{I_L} = 10$, this can be simplified to:

$$V_H - V_L = 1.986 \times 10^{-4} \times nT$$

The term “ n ” is called the ideality factor and is process-dependent. The value is quite close to 1.0 for most transistors. For example, Pentium® III microprocessors have an ideality factor of about 1.008, while Pentium IV microprocessors are about 1.002. A remote-diode temperature sensor generates currents with precise ratios, measures the resulting voltages, and then scales and level-shifts the voltage measurement to produce temperature data. The internal analog-to-digital converter (ADC) must be able to accurately measure small voltages with rather large common-mode values; a 1°C temperature change corresponds to approximately 200µV.

An extended-range temperature sensor is similar to a conventional sensor, but with a slightly larger ADC input-voltage range to accommodate the larger voltage differentials between the low and high current levels. Also, the temperature data must be organized differently. Maxim's extended-range temperature sensors add a higher-weighted MSB to permit temperature measurements above 128°C. This is usually done by replacing the sign bit with the larger MSB.

To produce a reliable, accurate, extended-range remote-diode temperature sensor, precise manufacturing test techniques must be employed to trim the sensor and verify its accuracy. Maxim's proprietary thermal-management test systems measure the temperature of the sensor and the thermal diode and trim the sensor's internal circuitry for accuracy that is unmatched in the industry.

Remote temperature sensors measure to 150°C

Maxim's first extended-range remote temperature sensor was the MAX6627, introduced in 2001. The MAX6627 is unique among remote temperature sensors because it has a 3-wire (clock, serial data out, and chip select) digital interface. It is available in the small, 8-pin SOT-23 package, which allows it to be located near critical components.

In 2003, Maxim introduced the MAX6646/MAX6647/MAX6649, three extended-range remote temperature sensors with a 2-wire, I²C™/SMBus™-compatible interface, which makes them particularly well suited for desktop, notebook, and server applications. These sensors have 1°C accuracy up to 145°C (**Figure 2**), making them the world's most accurate extended-range temperature sensors. They are pin-compatible with the industry-standard MAX6692, and are register-compatible as well. However, at 128°C and above, the temperature data registers have an additional data bit to allow higher temperature measurements. These sensors also include features such as thermal comparator outputs to indicate over- and undertemperature conditions, which are useful for monitoring and protecting high-performance ICs.

Another new extended-range sensor introduced in 2003 is the MAX6642 (**Figure 3**), the smallest extended-range temperature sensor available with an SMBus interface. It is packaged in a 6-pin TDFN with a 3mm x 3mm footprint of only 0.8mm thickness. Accuracy is guaranteed within ±1°C from 60°C to 100°C, and ±3.5°C from 100°C to 150°C.

Pentium is a registered trademark of Intel Corporation. Purchase of I²C components of Maxim Integrated Products, Inc., or one of its sublicensed Associated Companies, conveys a license under the Philips I²C Patent Rights to use these components in an I²C system, provided that the system conforms to the I²C Standard Specification as defined by Philips. SMBus is a trademark of Intel Corporation.

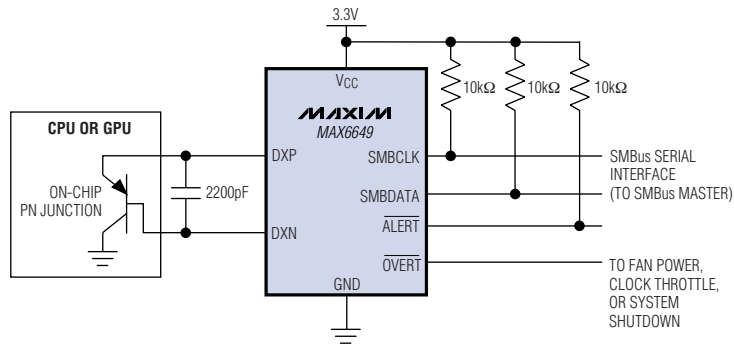

Figure 2. The MAX6649 measures thermal diodes on CPUs or graphics processors with 1°C accuracy from 60°C to 145°C. Temperatures up to 150°C can be measured with reduced accuracy.

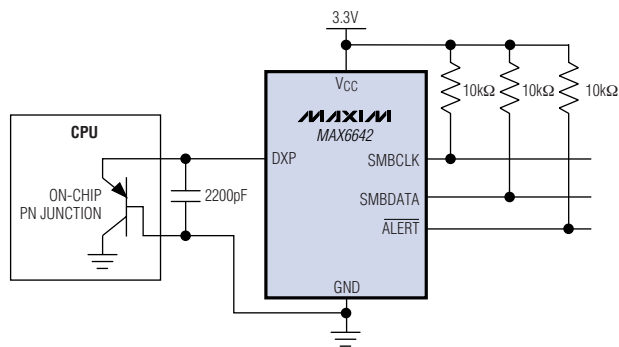

Figure 3. The MAX6642 is the world's smallest remote temperature sensor, measuring temperatures up to 150°C.

Summary

Although extended-range remote temperature sensors are new to the market, their need in a variety of current and future systems is clear. Maxim is committed to supplying the highest precision extended-range sensors in the industry and will continue to introduce innovative extended-range products that keep pace with emerging system requirements.

A similar article appeared in the January, 2004 issue of ECN.